

All-electrical frequency noise reduction and linewidth narrowing in quantum cascade lasers

Ilia Sergachev,^{1,*} Richard Maulini,¹ Alfredo Bismuto,¹ Stéphane Blaser,¹ Tobias Gresch,¹ Yves Bidaux,¹ Antoine Müller,¹ Stéphane Schilt,² and Thomas Südmeyer²

¹Alpes Lasers SA, 1-3 Max.-de-Meuron, CH-2001 Neuchâtel, Switzerland

²Laboratoire Temps-Fréquence, Institut de Physique, Université de Neuchâtel, CH-2000 Neuchâtel, Switzerland

Corresponding author: ilia.sergachev@alpeslasers.ch

A novel all-electrical method of frequency noise reduction in quantum cascade lasers (QCLs) is proposed. Electrical current through the laser was continuously adjusted to compensate for fluctuations of the laser internal resistance, which led to an active stabilization of the optical emission frequency. A reduction of the linewidth from 1.7 MHz in the standard constant current mode of operation down to 480 kHz is demonstrated at 10-ms observation time when applying this method to a QCL emitting at 7.9 μm .

OCIS codes: (140.5965) Semiconductor lasers, quantum cascade; (140.3425) Laser stabilization.
<http://dx.doi.org/10.1364/OL.39.006411>

Quantum cascade lasers (QCLs) [1] are known for offering a unique set of properties that make them the most attractive type of light source in the mid-infrared spectral region for various applications such as high-resolution spectroscopy or gas sensing. The linewidth of a free-running distributed feedback (DFB) quantum cascade laser is typically in range of 1–10 MHz [2,3], and can be reduced down to the kHz level when locked to an optical reference or to a stabilized frequency comb as reported in a number of recent studies [4–7].

Ultimate narrow-linewidth performance at the sub-10-Hz level has been recently reported for a QCL phase-locked to a secondary frequency standard made of a CO₂ laser stabilized onto a saturated absorption line of OsO₄ [8]. However, for some applications, like high-resolution spectroscopy, there is a challenge of narrowing the linewidth to a sub-MHz level while preserving the full tuning range of the laser. For this reason, the development of laser linewidth narrowing techniques that do not involve a fixed optical frequency reference and that can be implemented in a cost-effective integrated configuration is so attractive.

The proposed method is based on the previous observation that the QCL instantaneous optical frequency is strongly correlated (up to 90% [2]) to the voltage observed at the laser electrical contacts when operated in constant current mode. Therefore, the voltage noise across the laser can serve as an easily measurable error signal for a stabilization loop working at any operation condition of the QCL. In the previous approach reported in [2], the noise reduction was implemented by controlling the internal temperature of the QCL active region using a near-infrared laser illuminating the top surface of the QCL and thus partially absorbed in its structure.

Building on this previous work, we present here a novel method of QCL frequency noise reduction that also exploits the voltage noise measured at the laser contacts, but uses fast digital signal processing to directly stabilize the electrical power dissipated in the QCL by feedback to the laser injection current. For this purpose, a simple electrical model of the QCL was developed. The laser is represented as an active region with a differential

electrical resistance R_{diff} (which is assumed to be constant within a small current range) and a serially-connected noise resistance δR . In this model, the active region dissipates a constant electrical power when the QCL is operated in the standard constant current mode, and the overall electrical power fluctuations are induced by the instantaneous variations δR of the noise resistance. This leads to fast changes of the QCL internal temperature resulting in a modulation of the optical frequency as this latter directly varies with temperature at a typical tuning rate of $(1/\nu)d\nu/dT \approx 10^{-4} \text{ K}^{-1}$ [1]. To reduce the laser frequency fluctuations, electrical power variations must be compensated in either way. In the present work, we report on a novel method that does not imply any additional heater, but uses only a control of the laser injection current in an appropriate way. Therefore, the method does not require any additional optical component out of the laser and can thus be easily implemented with any type of QCL.

If one aims at reducing the frequency noise of a QCL using the measured voltage as an error signal for a proportional-integral (PI) servo-loop, the obtained correction signal cannot be directly applied to the laser injection current as it does not lead to any stabilization of the electrical power dissipated in the QCL. The reason is that, while the laser voltage noise is effectively reduced in this way (corresponding to an operation in constant voltage supply mode, see Fig. 3), injection current modulation is induced at the same time, leading to a dissipated power modulation of the same magnitude as in the non-stabilized case. Such a feedback loop only converts voltage noise into current noise, but the associated temperature and optical frequency fluctuations are basically unchanged. As neither a stable voltage nor a stable current alone leads to low-frequency noise operation of a QCL, it is important to produce a proper error signal that is directly proportional to the electrical power fluctuations, i.e., to the product of the QCL voltage and current. For the noise resistance model described here, the instantaneous power variations can be written as $\delta P(t) = I_0 \delta U(t)$, when the laser is driven by a constant current I_0 , where $\delta U(t)$ is the measured voltage

fluctuation induced by the noise resistance. Under the applied current corrections $dI(t)$, which are small compared to the average current I_0 , the instantaneous power variations become in first-order approximation $\delta P(t) = U_0 dI(t) + I_0 \delta U(t)$, where U_0 is the average voltage drop across the laser corresponding to I_0 . Therefore, four parameters are needed to calculate the error signal $\delta P(t)$: the average voltage U_0 and current I_0 , and their instantaneous variations δU and dI , respectively. From this error signal, a control of the laser current can be applied via a PI servo-controller to stabilize the electrical power applied to the laser and thus reduce the optical frequency fluctuations. It is important to emphasize that this way of controlling of laser current does not impose any restrictions on laser operation temperature and current and, therefore, preserves full range of the optical frequency tuning.

The signal processing described here was implemented in a commercially available field-programmable gate array (FPGA) evaluation board with fast 14-bit ADC and 14-bit DAC. The ADC and DAC were operating at 20 MHz, and the overall reaction time of the output signal to a change of the input signal was 7 ns. The average values of the QCL voltage and current were not measured by the FPGA-board, but were accounted for in the processing algorithm as user changeable parameters, as they remained constant during the stabilization experiment. This is justified as the stabilization method presented here corrects for fast-frequency fluctuations of the QCL to reduce its linewidth, but does not compensate for the long-term wavelength drift of the laser. The small variation dI of the laser current caused by the stabilization was also not measured, but calculated from multiple output values of the stabilization algorithm corresponding to the previous time steps. Therefore, only one parameter was measured in real-time by the FPGA-board, i.e., the laser voltage fluctuations δU , and one ADC was sufficient to produce the error signal. A scheme of the implemented experimental setup is displayed in Fig. 1.

The QCL under test was driven by a low-noise current source developed at Laboratoire Temps-Fréquence, with a typical current noise density lower than $1 \text{ nA}/\sqrt{\text{Hz}}$ at all frequencies above 1 kHz. This noise level is sufficiently small to insure that it does not induce any additional linewidth broadening of the QCL [9]. The voltage noise measured at the QCL contacts was amplified using an AC-coupled low-noise preamplifier (Signal Recovery

model 5113) with a gain of 34 dB, low cut-off frequency of about 1 Hz, and high cut-off frequency of 300 kHz (which was in this experiment the limitation for overall loop bandwidth), and was continuously processed by the FPGA-based board. The fluctuations of the electrical power dissipated in the QCL were calculated from the measured amplified voltage fluctuations combined with the other parameters stored in the FPGA. The output signal of the board, i.e., the calculated drive current correction dI necessary to minimize the dissipated power fluctuations, was fed as an input voltage into the modulation port of the laser current source. To characterize the spectral properties of the stabilized laser, its emission wavelength was tuned to the flank of an N_2O gas absorption line obtained from a 10-cm-long sealed gas cell filled at 2 mbar pressure and acting as a frequency discriminator. A fast thermo-electrically cooled MCT detector (Vigo PVI-4TE-08) measured the optical power transmitted through the gas cell, in which the laser frequency noise has been converted into amplitude noise by the linear slope of the N_2O transition. The output signal of the amplified photodiode was analyzed with a fast Fourier transform (FFT) spectrum analyzer (Stanford Research System SR770) to measure the laser frequency noise power spectral density (PSD). For the demonstration of our new frequency noise reduction technique, we have compared two $7.9\text{-}\mu\text{m}$ DFB buried-heterostructure QCLs produced by Alpes Lasers, which demonstrated very similar results. Therefore, experimental results are shown here for only one of them. The laser was operated at 15°C and was precisely temperature-stabilized at the mK level using a temperature controller that is part of the low-noise QCL control electronics. The laser was operated at a constant current of 0.7 A and a corresponding voltage drop of 12 V, with an output optical power of 20 mW.

The calibration of the N_2O absorption line used as a frequency discriminator was obtained by spectroscopic measurements. First, a laser current scan performed from 690 to 740 mA at a constant temperature of 15°C was used to reveal two N_2O absorption lines at 1272.85352 and $1272.29068 \text{ cm}^{-1}$ [10]. The center frequencies of these transitions were used to determine the laser current-tuning rate of $434.7 \text{ MHz}/\text{mA}$. Then a narrower scan of a single absorption line was realized with 0.01-mA current steps to precisely determine the slope of the linear range on the side of the absorption line. The measured discriminator slope $D = 0.921 \text{ V}/\text{MHz}$ was used to convert the noise spectra measured at the output of the photodiode and recorded by the FFT spectrum analyzer into laser frequency noise.

Figure 2 illustrates the effect of the all-electrical frequency noise reduction method applied to our QCL by comparing the frequency noise PSD measured on the side of the N_2O absorption line for the free-running and stabilized QCL. A uniform reduction of the frequency noise PSD by one order of magnitude is achieved up to a frequency of 100 kHz, which was the upper limit of our FFT spectrum analyzer. The QCL frequency noise reduction factor achieved here is comparable to the one previously obtained when controlling the QCL internal temperature using an external near-infrared laser [2]. However, the new method proposed here is simpler to

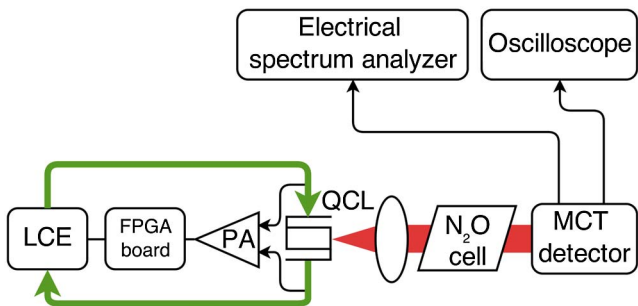

Fig. 1. Scheme of the experimental setup. LCE, laser control electronics (current driver and temperature controller); PA, preamplifier, bold arrows represent electrical current through the QCL.

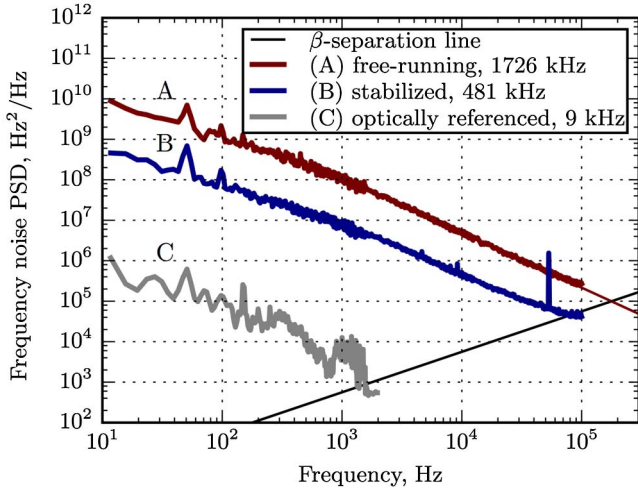

Fig. 2. Frequency noise PSD of the QCL measured in free-running (A) and stabilized (B) conditions. The thin line above 100 kHz for the free-running QCL is an extrapolation of the $1/f$ noise used for the linewidth determination. The “C” curve shows the frequency noise reduction achieved when stabilizing the QCL frequency to the side of the N_2O transition using the same stabilization electronics and the optical signal from the MCT detector as an error signal. The corresponding full width at half-maximum (FWHM) linewidth of the laser calculated using the concept of the β -separation line [11] is also indicated in each case (at 10-ms observation time).

implement as it does not require any additional optical component out of the QCL. The corresponding full width at half-maximum (FWHM) of the QCL emission line calculated using the β -separation line approximation described in [11] is reduced from 1730 kHz for the free-running laser down to 480 kHz for the stabilized laser (at 10 ms observation time). For the free-running QCL, the noise at frequencies higher than 100 kHz still contributes to the laser linewidth and the crossing-point of the noise spectrum with the β -separation line (which corresponds to the upper integration limit for the linewidth determination) was estimated to be 177 kHz by extrapolating the $1/f$ noise to higher frequencies (thin line in Fig. 2). Figure 2 also presents the QCL frequency noise obtained using the same stabilization electronics, but in the case of an optical stabilization to the side of the N_2O absorption line, using the signal of the MCT detector instead of the computed electrical power as an error signal. While the QCL is not tunable in this case, a much lower frequency noise is achieved, which indicates that the effectiveness of the noise reduction achieved with the stabilization of the electrical power is limited by the partial voltage-to-frequency noise correlation and not by the stabilization electronics. In addition to the frequency noise, the intensity noise spectrum of the QCL was also measured in free-running and stabilized operation modes. The measurement was made using the same setup as shown in Fig. 1, but without the gas cell. No measurable change of the laser intensity noise was observed.

Figure 3 presents the laser voltage noise PSD measured for the QCL operated in free-running mode (curve “D”) and with the electrical power stabilization activated (curve “E”). Only a tiny reduction of the voltage noise is

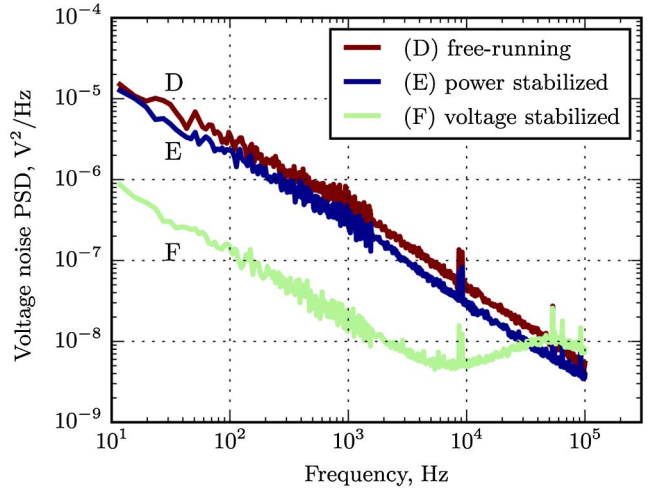

Fig. 3. Voltage noise power spectral density compared for the free-running and stabilized QCL. The “E” curve corresponds to the main result of this work with laser electrical power stabilized. The “F” curve shows the limit to which voltage noise can be PI-suppressed.

observed when the stabilization is activated, which is much smaller than the reduction of the frequency noise shown in Fig. 2. In addition, the lower voltage noise achieved when using the QCL voltage fluctuations as the error signal for the PI-loop instead of the calculated electrical power is also displayed in Fig. 3. Despite of the higher decrease of the voltage noise, no optical frequency noise reduction is achieved in this case as explained before.

The fluctuations of the QCL voltage and optical frequency were simultaneously recorded by a digital oscilloscope over a timescale of 20 ms when the stabilization was activated as shown in Fig. 4. The corresponding fluctuations of the QCL electrical power (as calculated by the FPGA) are also displayed in the figure. The effectiveness of the loop to reduce the fluctuations of the electrical power dissipated in the QCL is clearly seen when the loop is activated ($t > 10$ ms), which results in a corresponding decrease of the optical frequency

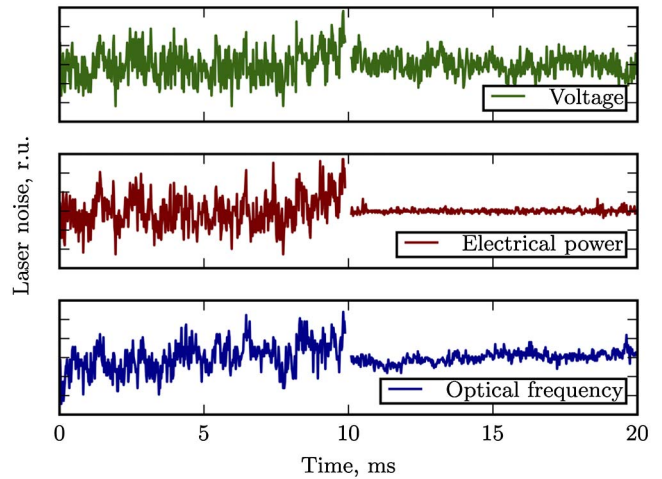

Fig. 4. Simultaneous time series of the measured voltage, calculated electrical power and measured optical frequency fluctuations for the free-running ($t < 10$ ms) and stabilized ($t > 10$ ms) QCL.

fluctuations. It is interesting to notice that in this case, neither the QCL voltage, nor the current, is stable (as the current constitutes the feedback signal), but only the electrical power is stabilized. From the recorded time series, the correlation coefficient between the fluctuations of the optical frequency and QCL voltage has been calculated, leading to a value of 0.75 for the free-running laser and 0.02 for the stabilized laser. This indicates that the contribution to the laser frequency noise originating from electrical power fluctuations is efficiently reduced.

The principal limitation of this kind of noise reduction technique arises from the imperfect correlation between QCL voltage noise and frequency noise. However, it is important to emphasize that the approach described here can be used with virtually any QCL. More than that, a correlation between optical and electrical noise was also observed in traditional interband semiconductor lasers [12,13], so that the proposed method could be used for stabilization of those devices too.

Alpes Lasers acknowledges financial support from the European Commission under the Seventh Framework Programme FP7 GA 607491 COMIQ. University of Neuchâtel acknowledges support from the Swiss National Science Foundation.

References

1. S. Blaser, D. A. Yarekha, L. Hvozďara, Y. Bonetti, A. Müller, M. Giovannini, and J. Faist, *Appl. Phys. Lett.* **86**, 041109 (2005).
2. L. Tombez, S. Schilt, D. Hofstetter, and T. Südmeyer, *Opt. Lett.* **38**, 5079 (2013).
3. S. Bartalini, S. Borri, P. Cancio, A. Castrillo, I. Galli, G. Giusfredi, D. Mazzotti, L. Gianfrani, and P. De Natale, *Phys. Rev. Lett.* **104**, 083904 (2010).
4. I. Galli, M. Siciliani de Cumis, F. Cappelli, S. Bartalini, D. Mazzotti, S. Borri, A. Montori, N. Akikusa, M. Yamanishi, G. Giusfredi, P. Cancio, and P. De Natale, *Appl. Phys. Lett.* **102**, 121117 (2013).
5. F. Cappelli, I. Galli, S. Borri, G. Giusfredi, P. Cancio, D. Mazzotti, A. Montori, N. Akikusa, M. Yamanishi, and S. Bartalini, *Opt. Lett.* **37**, 4811 (2012).
6. R. M. Williams, J. F. Kelly, J. S. Hartman, S. W. Sharpe, M. S. Taubman, J. L. Hall, F. Capasso, C. Gmachl, D. L. Sivco, and J. N. Baillargeon, *Opt. Lett.* **24**, 1844 (1999).
7. F. Bielsa, A. Douillet, T. Valenzuela, J.-P. Karr, and L. Hilico, *Opt. Lett.* **32**, 1641 (2007).
8. P. L. T. Sow, S. Mejri, S. K. Tokunaga, O. Lopez, A. Goncharov, B. Argence, C. Chardonnet, A. Amy-Klein, C. Daussy, and B. Darqui, *Appl. Phys. Lett.* **104**, 264101 (2014).
9. L. Tombez, S. Schilt, J. Francesco, T. Führer, B. Rein, T. Walther, G. Domenico, D. Hofstetter, and P. Thomann, *Appl. Phys. B* **109**, 407 (2012).
10. L. S. Rothman, I. E. Gordon, A. Barbe, D. C. Benner, P. F. Bernath, M. Birk, V. Boudon, L. R. Brown, A. Campargue, J.-P. Champion, K. Chance, L. H. Coudert, V. Dana, V. M. Devi, S. Fally, J.-M. Flaud, R. R. Gamache, A. Goldman, D. Jacquemart, I. Kleiner, N. Lacome, W. J. Lafferty, J.-Y. Mandin, S. T. Massie, S. Mikhailenko, C. E. Miller, N. Moazzen-Ahmadi, O. V. Naumenko, A. Nikitin, J. Orphal, A. Predoi-Cross, V. Perevalov, A. Perrin, C. P. Rinsland, M. Rotger, M. Šimečková, M. A. H. Smith, K. Sung, S. Tashkun, J. Tennyson, R. A. Toth, A. C. Vandaele, and J. Vander Auwera, *J. Quant. Spect. Rad. Trans.* **110**, 533 (2009).
11. G. Di Domenico, S. Schilt, and P. Thomann, *Appl. Opt.* **49**, 4801 (2010).
12. R. Soref, *IEEE J. Quantum Electron.* **5**, 126 (1969).
13. B. Orsal, P. Signoret, J.-M. Peransin, K. Daulasim, and R. Alabedra, *IEEE Trans. Electron Dev.* **41**, 2151 (1994).